

6

The 4/15 Base has its own diagram.

1.

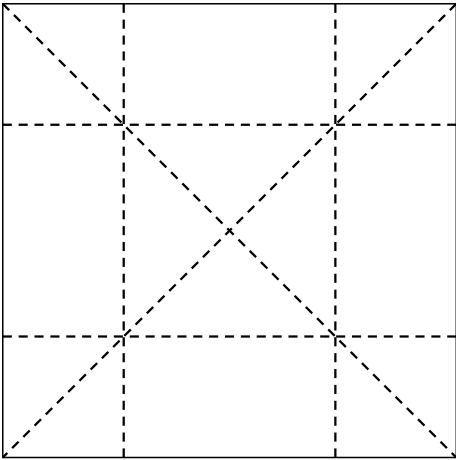

Crease the 4/15 Base.

2.

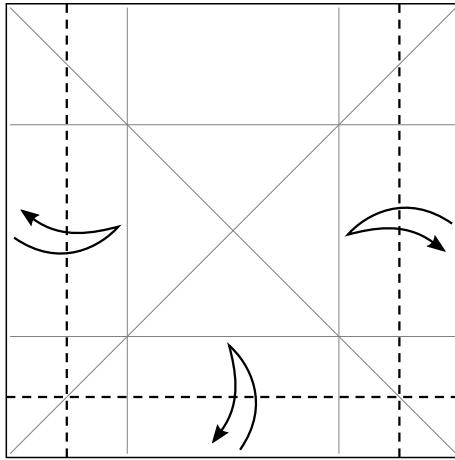

Fold the edges to the creases and unfold.

3.

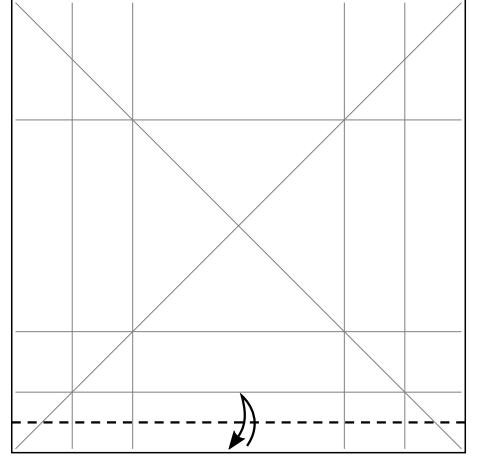

Fold the edge to the crease and unfold.

4.

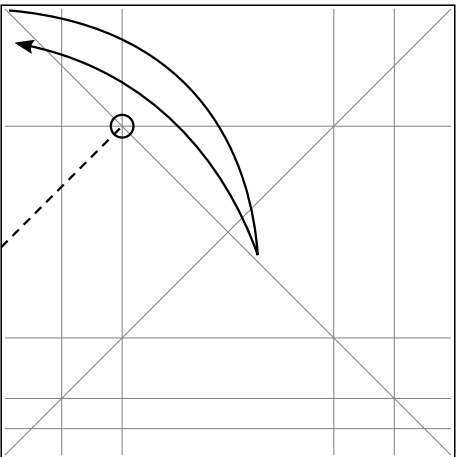

Bring the corner to the diagonal and crease up to the circled point.

5.

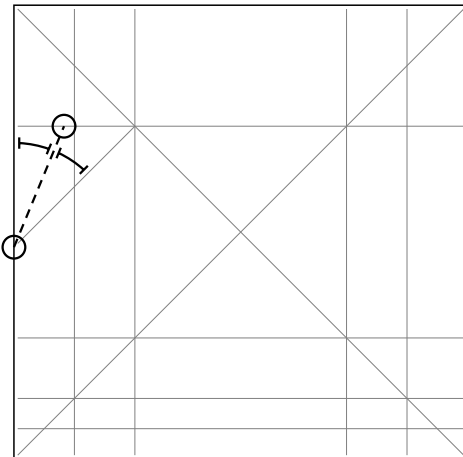

Crease the angle bisector.

6.

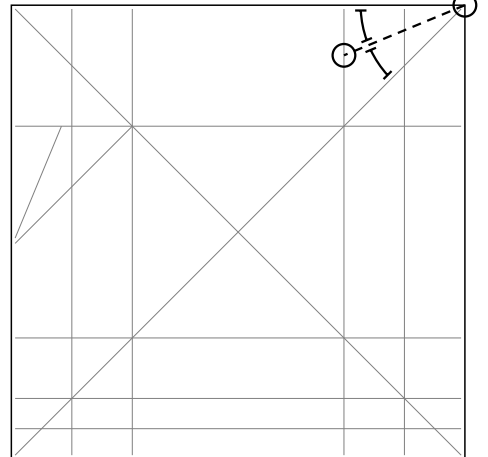

Crease the angle bisector.

7.

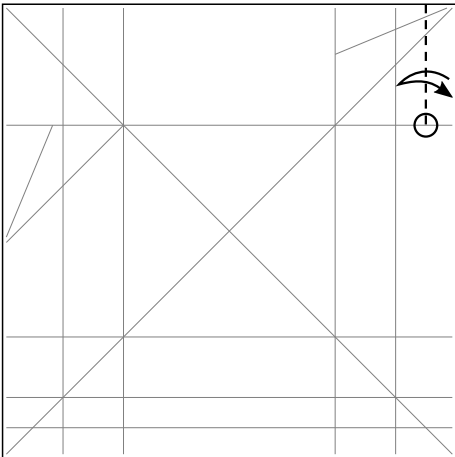

Bring the edge to the crease and crease up to the circled point.

8.

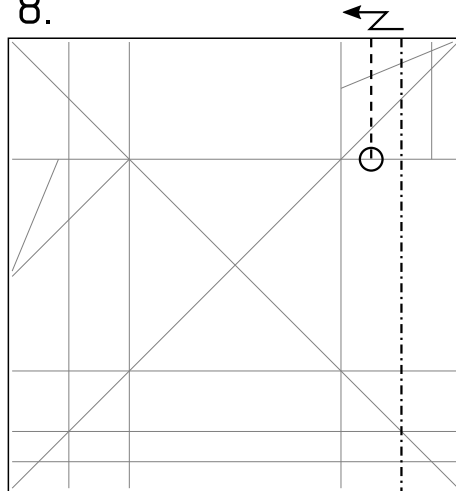

Partially pleat and unfold.

9.

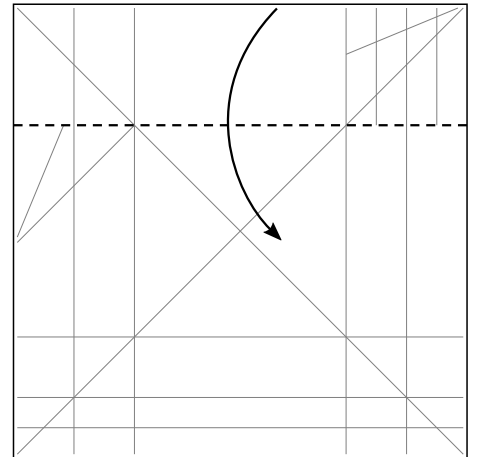

10.

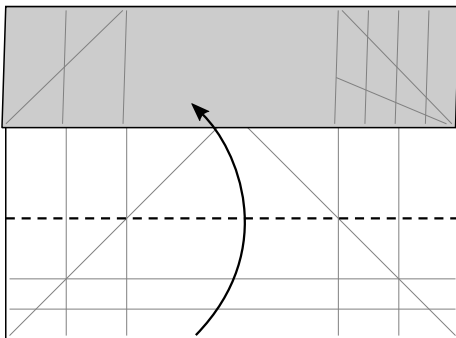

11.

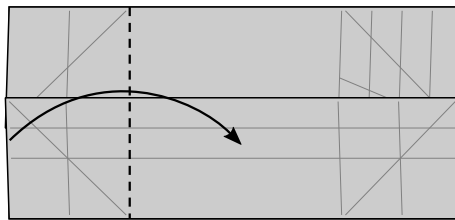

12.

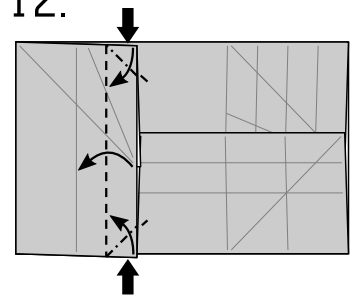

Squash-fold the edge to the crease.

13.

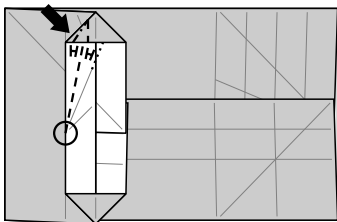

Squash-fold the angle bisector.

14.

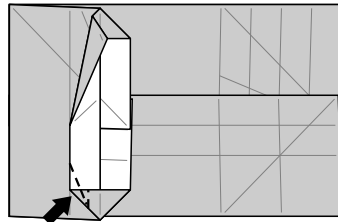

Squash-fold to round the corner, folding to taste.

15.

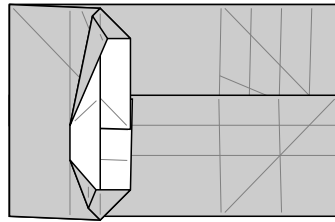

Like this.

16.

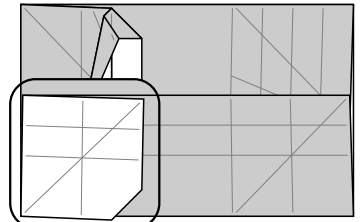

X-ray view.

17.

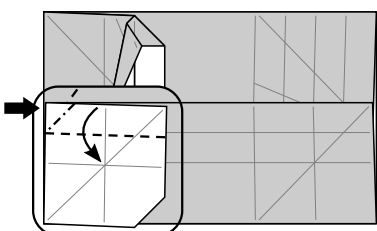

Squash-fold.

18.

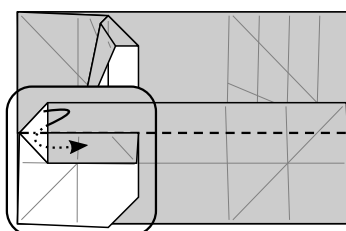

Reverse-fold.

19.

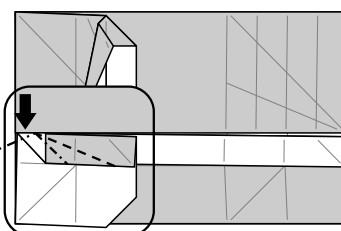

Squash-fold to round the corner, folding to taste.

20.

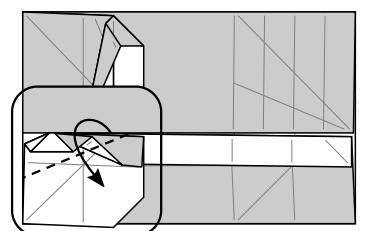

Round the corner, folding to taste.

21.

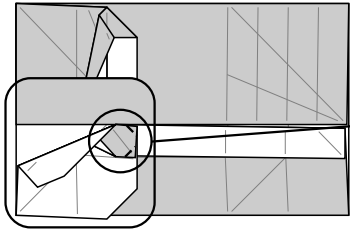

Round the corners,
folding to taste.

22.

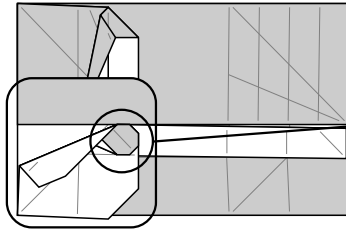

Like this.
Return to normal view.

23.

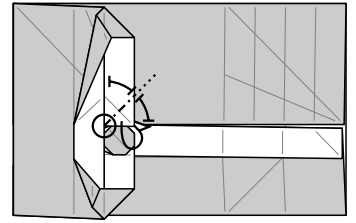

Fold the angle bisector
inward.

24.

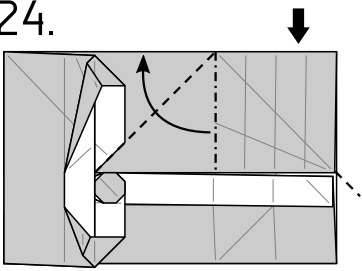

Squash-fold the crease
to the edge.

25.

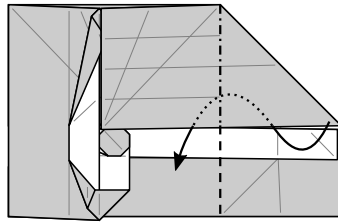

Reverse-fold.

26.

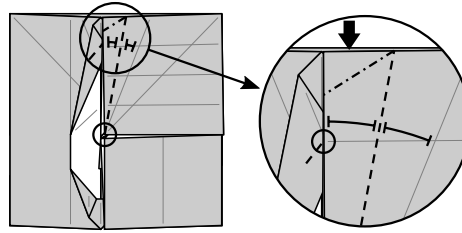

Squash-fold the
angle bisector.

27.

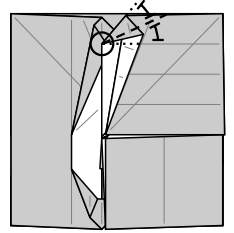

Fold the
angle bisector.

28.

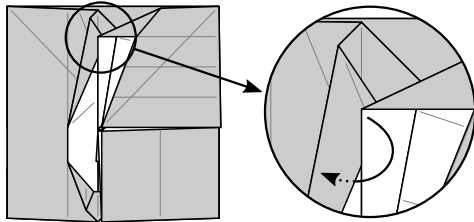

Tuck one layer.

29.

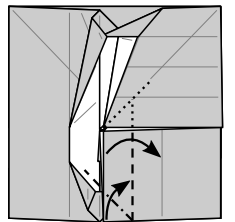

Squash-fold the
edge to the crease.

30.

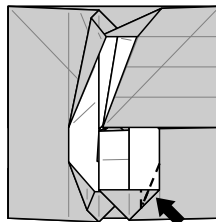

Squash-fold to
round the corner,
folding to taste.

31.

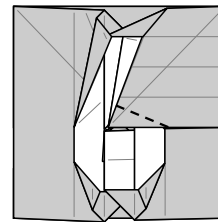

Round the corner,
folding to taste.

32.

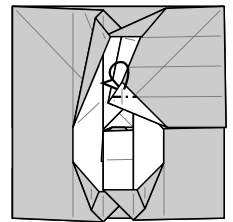

Fold inward, lining
up the fold with
the crease behind.
The tip will bend.
Squash it down.

33.

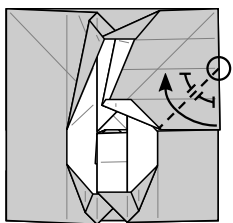

Fold the
angle bisector.

34.

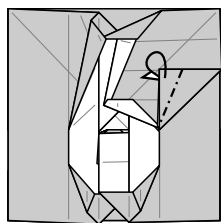

Fold inward to
hide the wrong-
color seam. The
fold does not quite
touch the corner.

35.

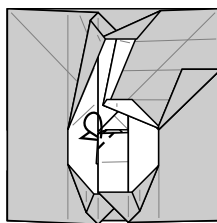

Fold the corner
inward.

36.

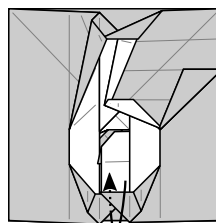

Tuck underneath.

37.

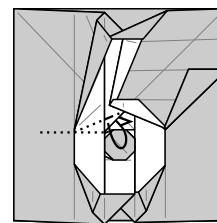

Fold inward to
hide the wrong-
color point.

38.

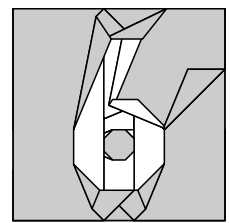

Finished!