

# 3

The 4/15 Base has its own diagram.

1.

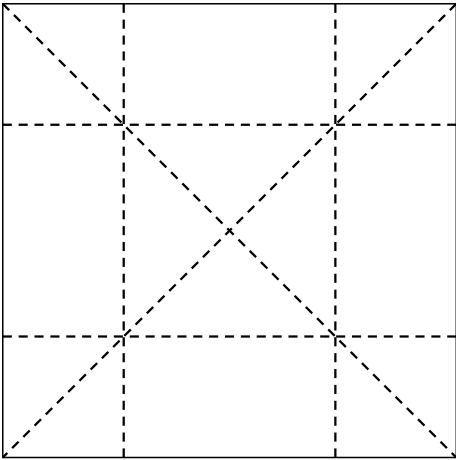

Crease the 4/15 Base.

2.

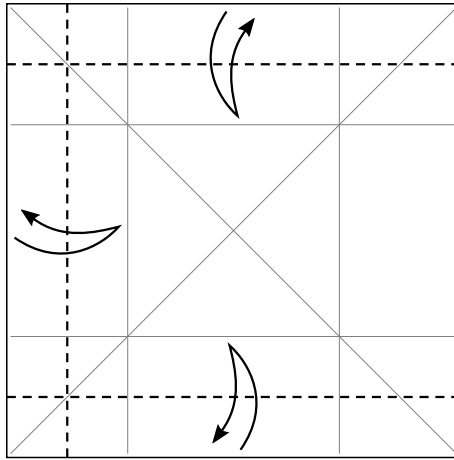

Fold the edges to the creases and unfold.

3.

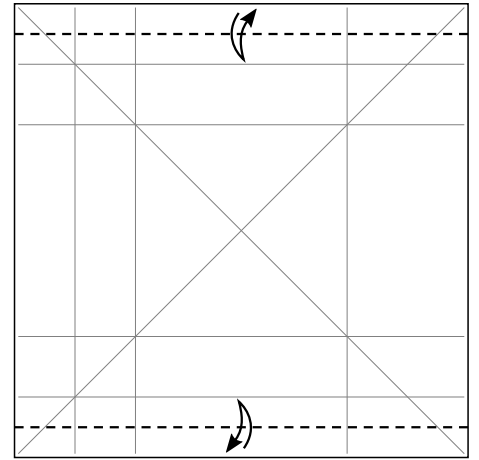

Fold the edges to the creases and unfold.

4.

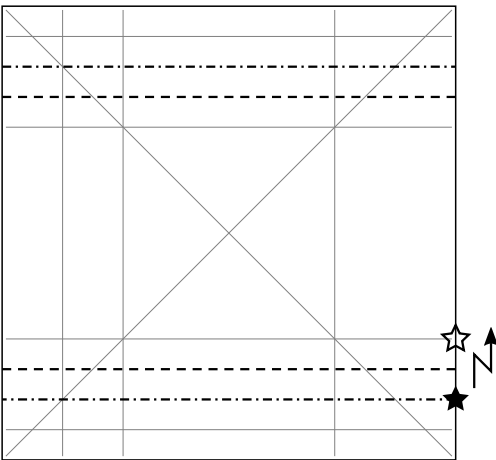

Pleat and unfold twice, maintaining symmetry.

5.

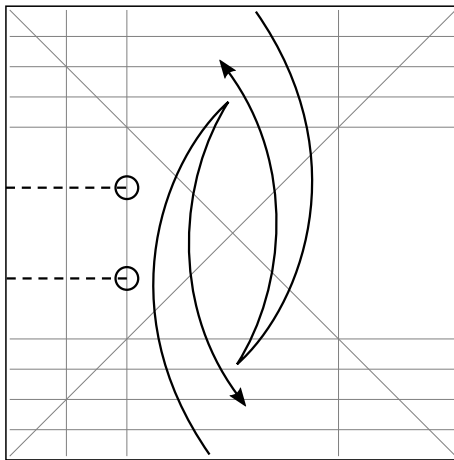

Bring the edges to the creases and crease up to the circled points.

6.

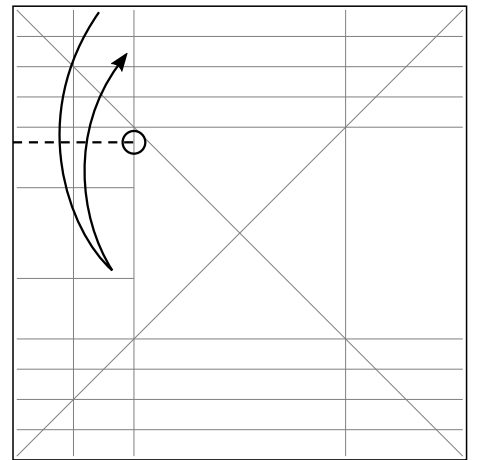

Bring the edge to the crease and crease up to the circled point.

7.

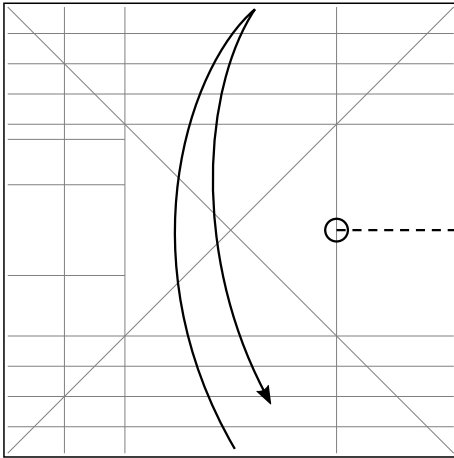

Bring the edge to the edge and crease up to the circled point.

8.

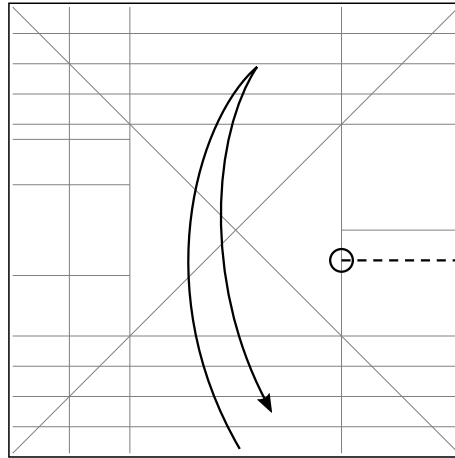

Bring the edge to the crease and crease up to the circled point.

9.

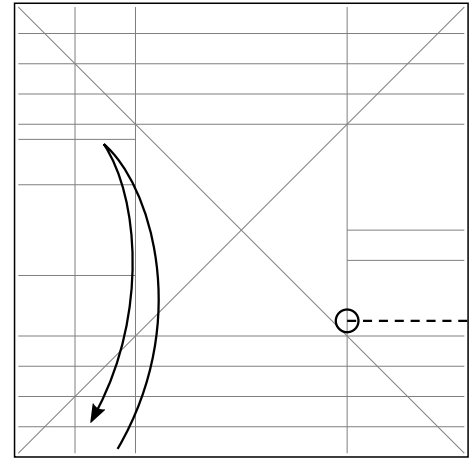

Bring the edge to the crease and crease up to the circled point.

10.

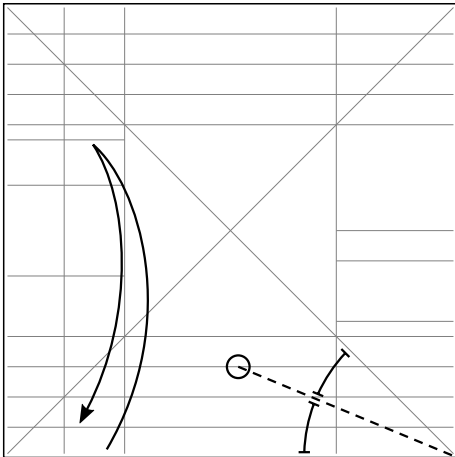

Crease the angle bisector.

11.

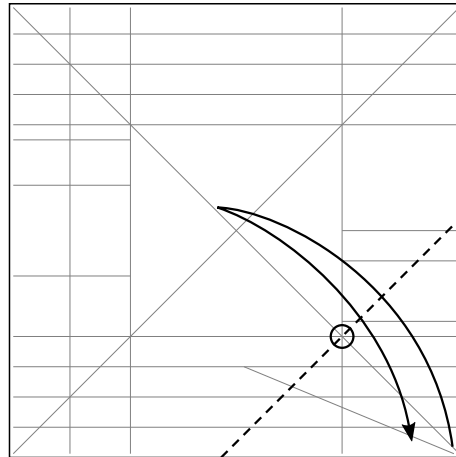

Bring the corner to the diagonal and crease.

12.

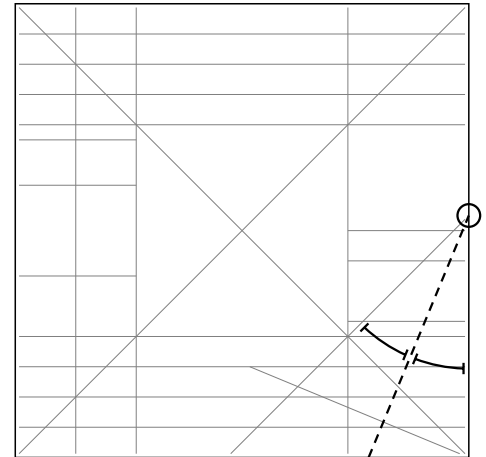

Crease the angle bisector.

13.

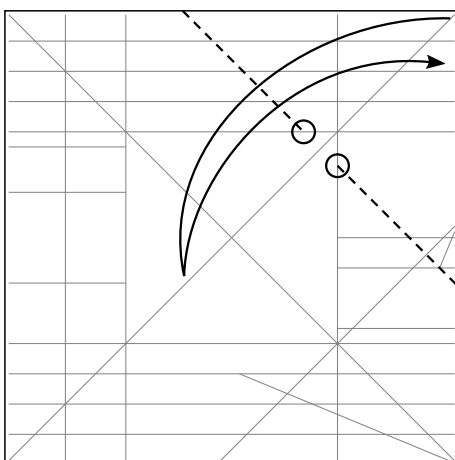

Bring the corner to the diagonal and crease, avoiding the square in the middle.

14.

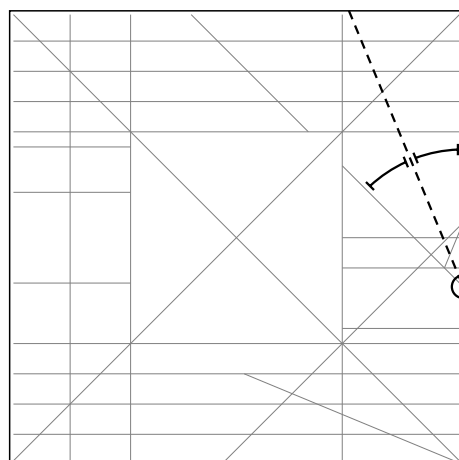

Crease the angle bisector.

15.

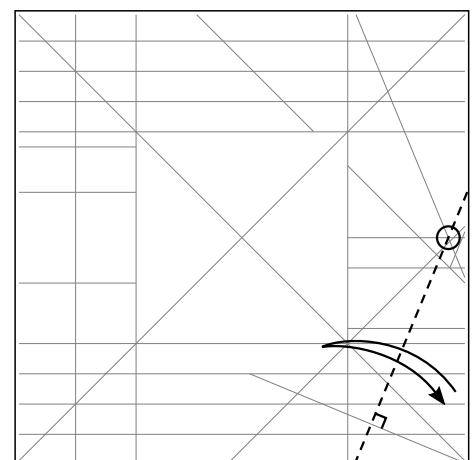

Crease at the intersection of Step 7's and Step 14's creases.

16.

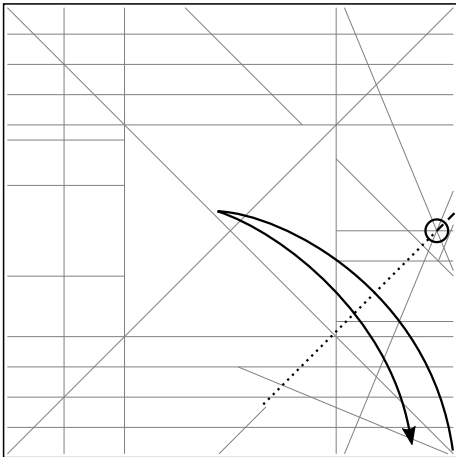

Bring the corner to the diagonal and make a small crease at the intersection of Step 7's and Step 14's creases.

17.

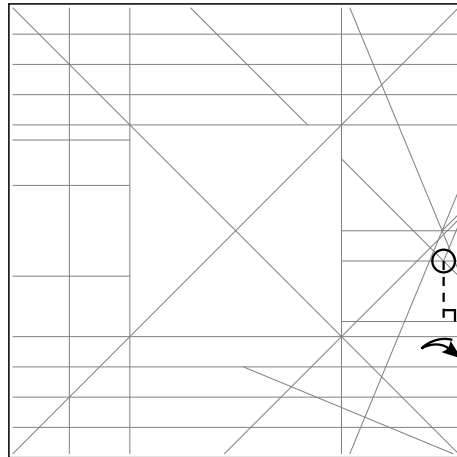

18.

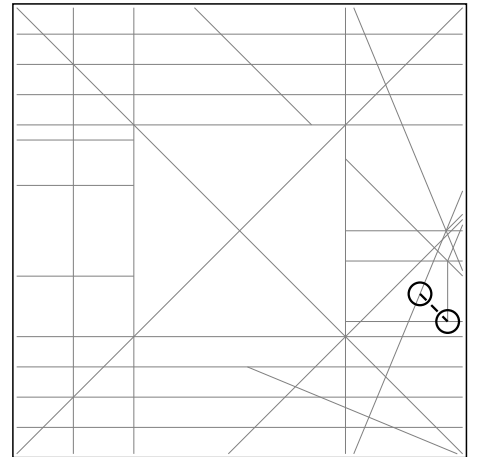

Bring the corner to the diagonal and crease between the circled points.

19.

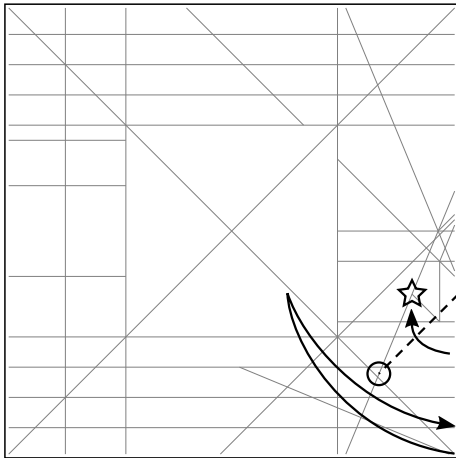

Bring the corner to the diagonal and the edge to the starred point and crease up to the circled point.

20.

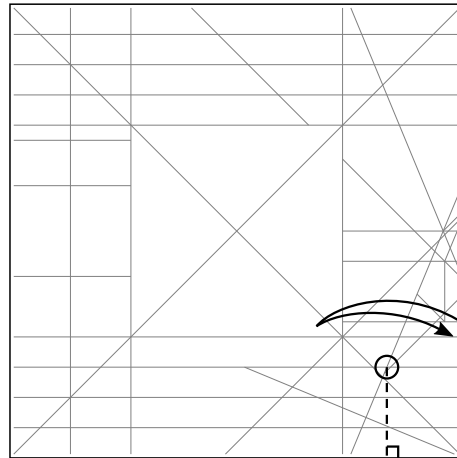

Crease up to the intersection of Step 4's and Step 15's creases.

21.

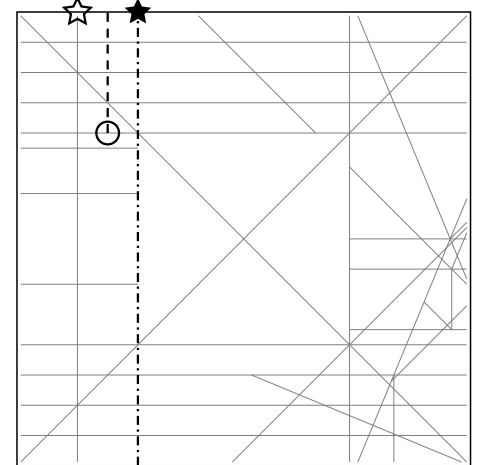

Partially pleat and unfold.

22.

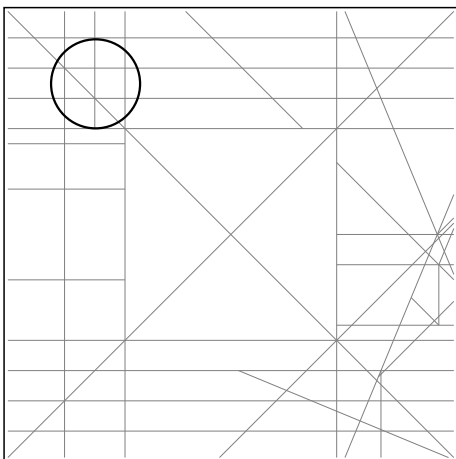

Zoom in.

23.

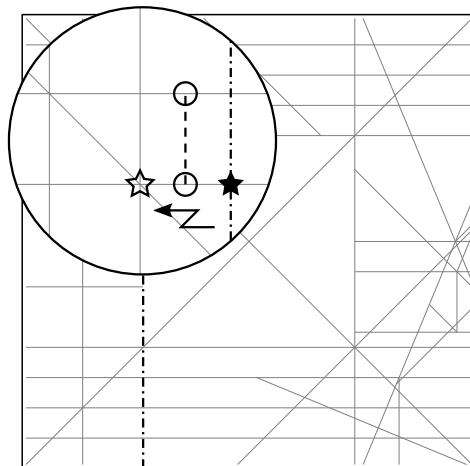

Partially pleat and unfold.

24.

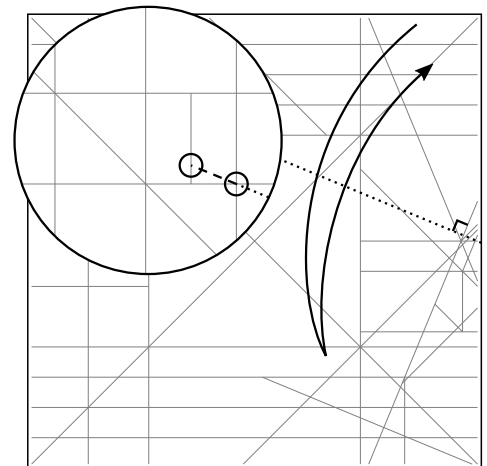

Crease between the circled points.

25.

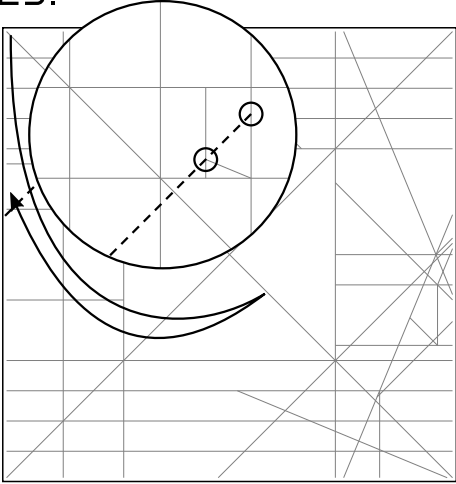

Bring the corner to the diagonal and crease up to the higher circled point.  
Zoom out.

26.

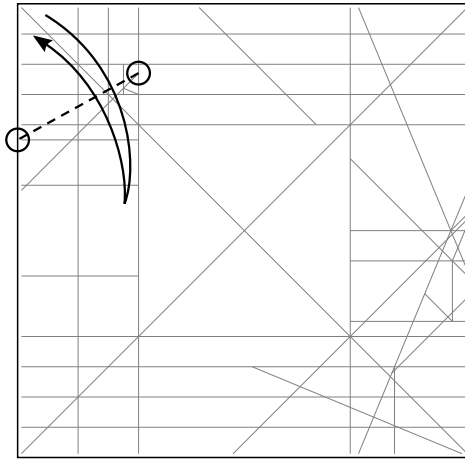

Crease between the circled points.

27.

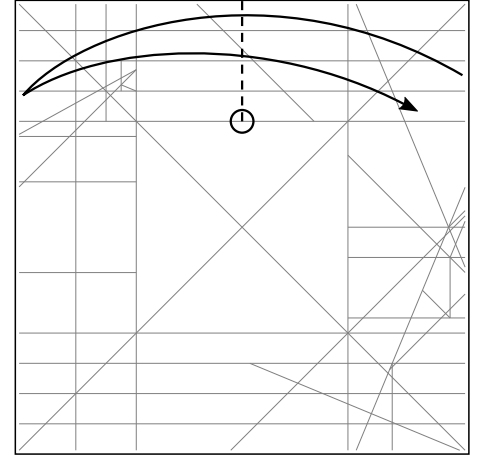

Bring the edge to the edge and crease up to the circled point.

28.

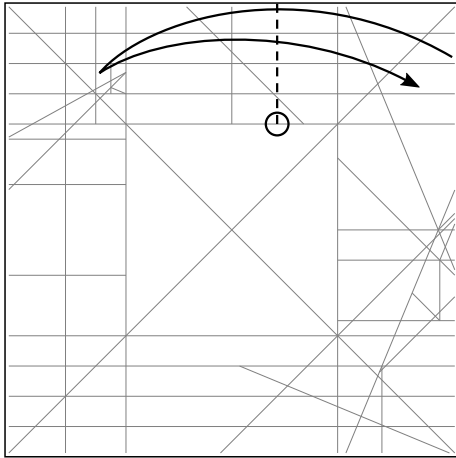

Bring the edge to the crease and crease up to the circled point.

29.

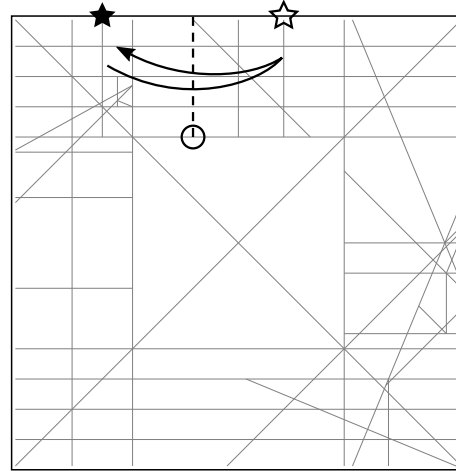

Bring the starred points together and crease up to the circled point.

30.

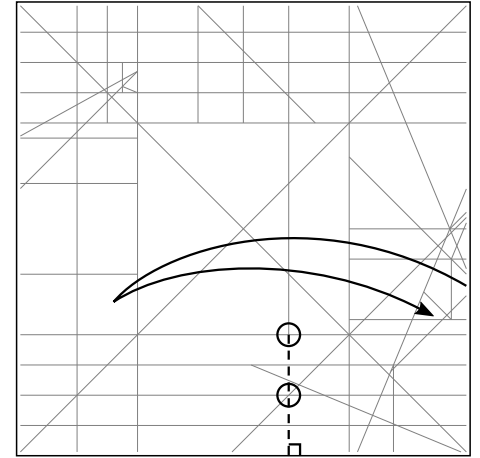

Crease up to the higher circled point.

31.

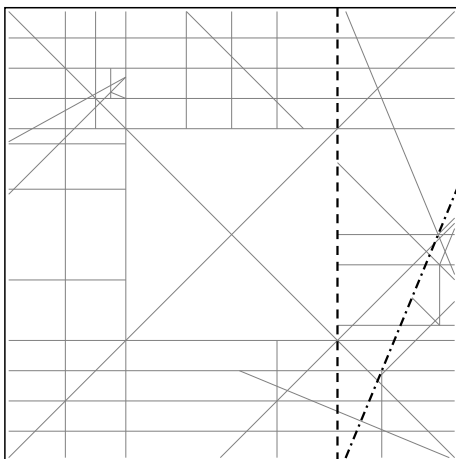

Crimp. ← Z

32.

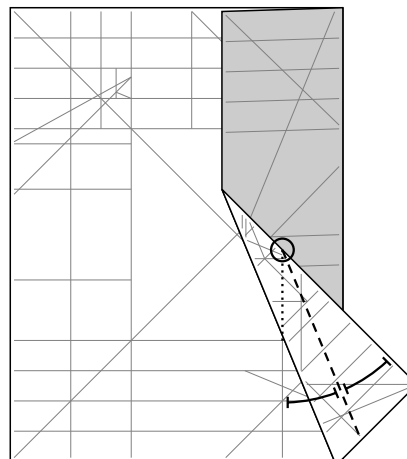

Crease the angle bisector.

33.

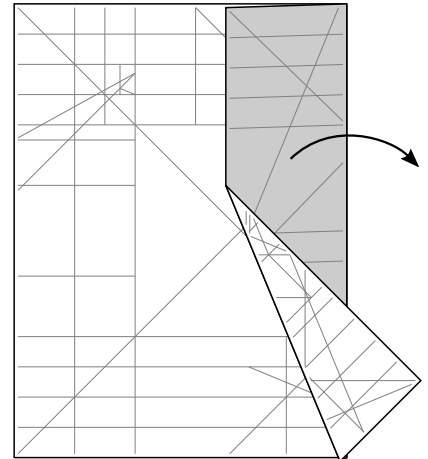

Unfold everything.

34.

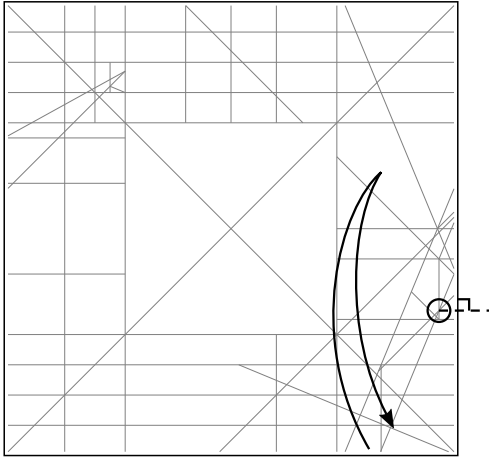

Crease up to the circled point.

35.

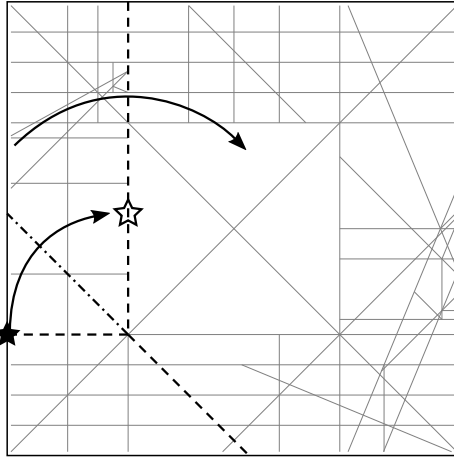

Collapse. The diagonal is a new crease.

36.

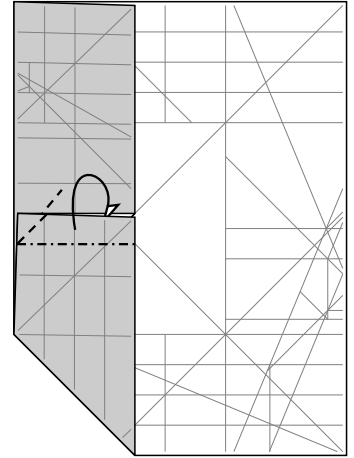

Squash-fold inward.

37.

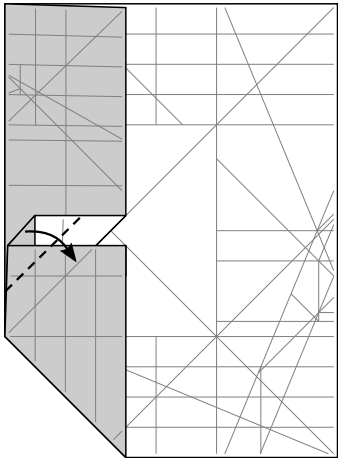

Fold the edge to the crease.

38.

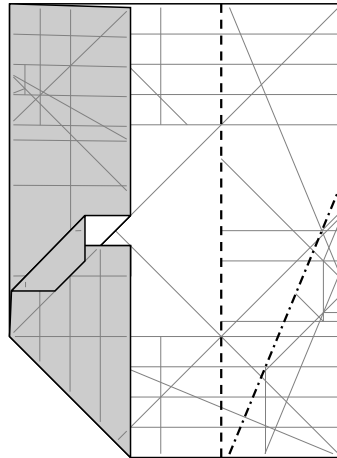

Crimp.

39.

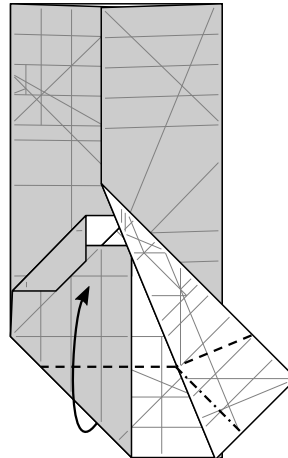

Squash-fold.

40.

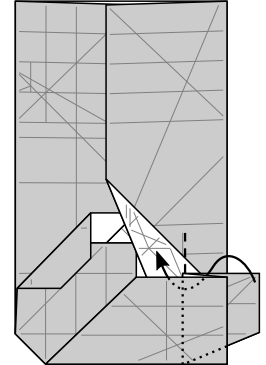

Inside-reverse-fold. There will be a narrow pleat.

41.

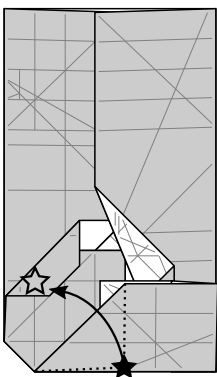

Untuck the corner underneath.

42.

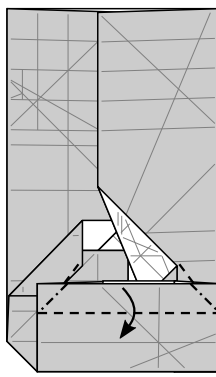

Squash-fold.

43.

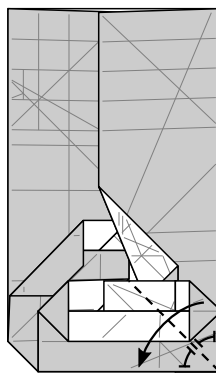

Fold the angle bisector.

44.

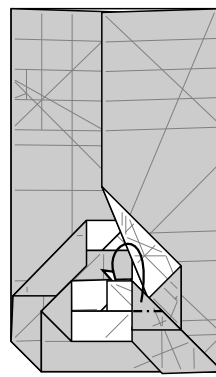

Fold the corner inward.

45.

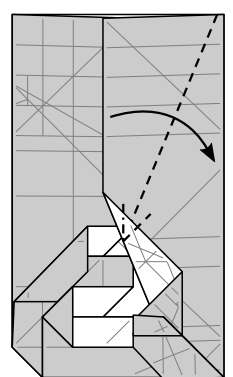

Squash-fold.

46.

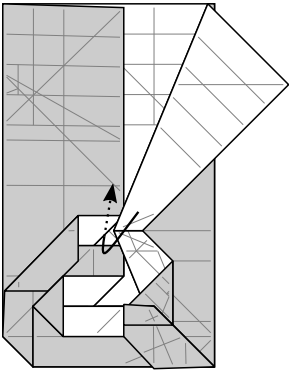

Tuck one layer underneath.

47.

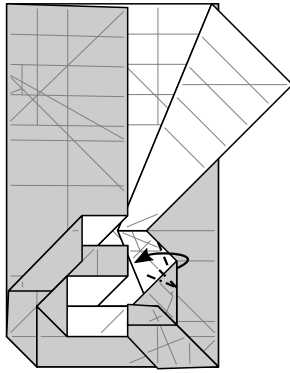

Squash-fold inward.

48.

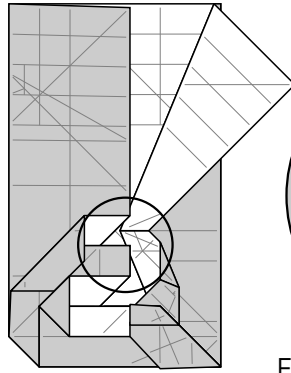

Zoom in.

49.

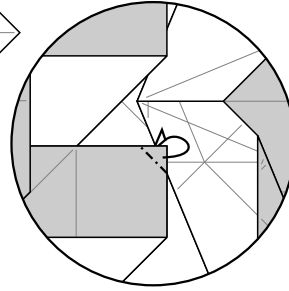

Fold the corner inward to taste.

50.

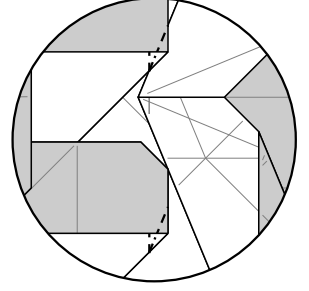

Round the corners, squash-folding to taste.

51.

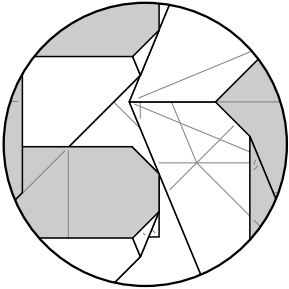

Like this. Zoom out.

52.

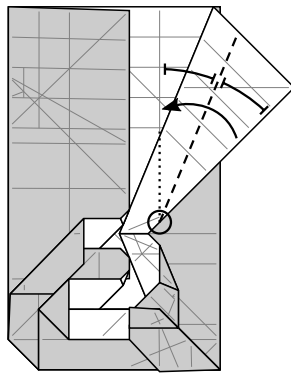

Fold the angle bisector.

53.

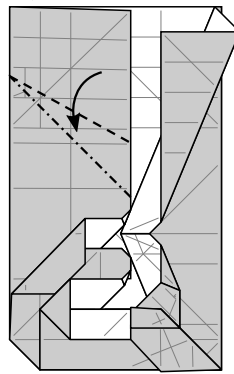

Squash-fold inward.

54.

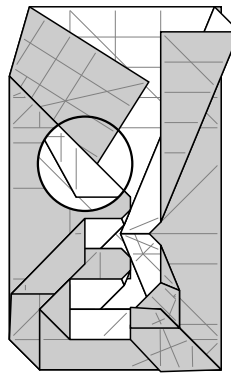

X-ray view.

55.

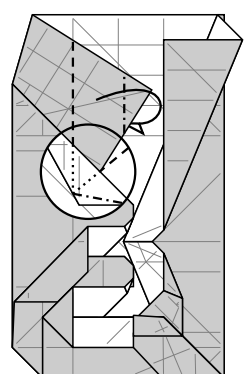

Swivel-fold inward, lining up the fold with the crease behind. The tip will bend a little. Fold it away.

56.

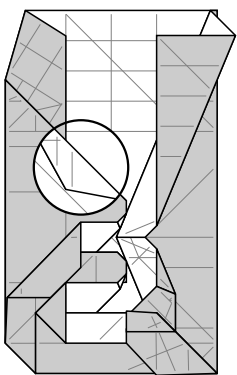

Like this. Return to normal view.

57.

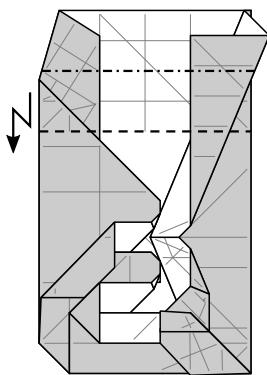

Pleat.

58.

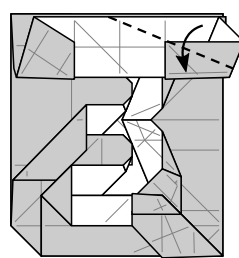

Round the corner, folding to taste.

59.

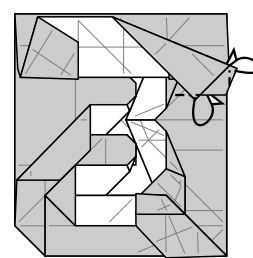

Fold the corners inward.

60.

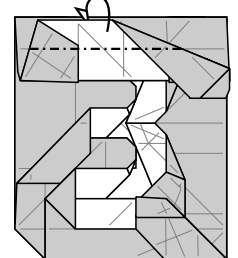

Fold the edge inward.

61.

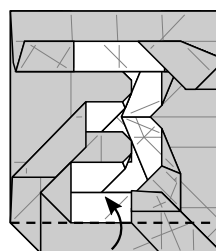

62.

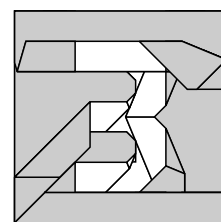

Finished!