

0

1.

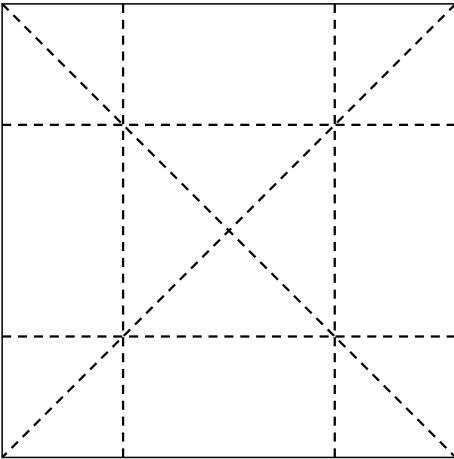

Crease the 4/15 Base.

2.

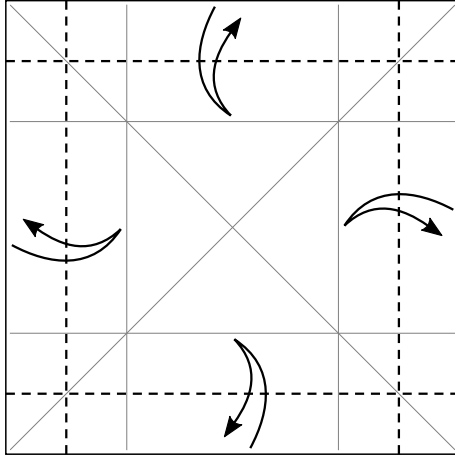

Fold the edges to the creases and unfold.

3.

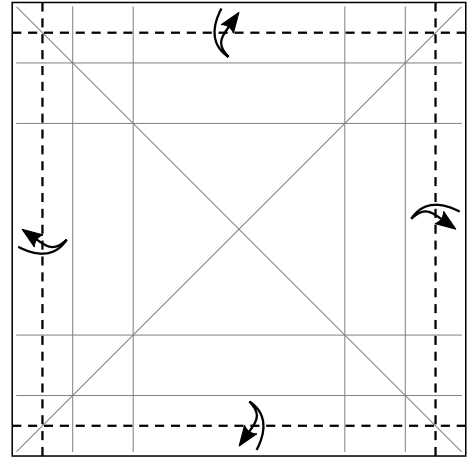

Fold the edges to the creases and unfold.

4.

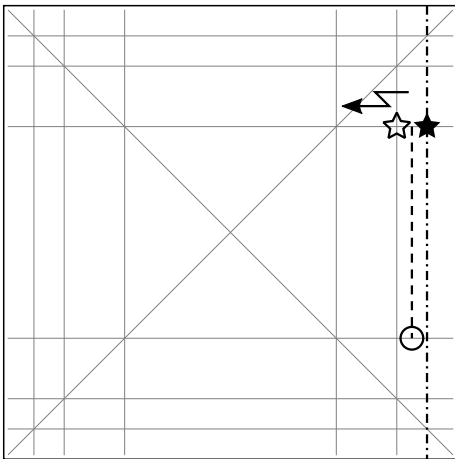

Partially pleat and unfold.

5.

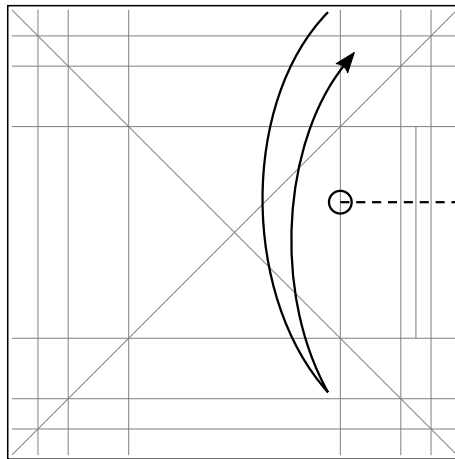

Bring the edge to the crease and crease up to the circled point.

6.

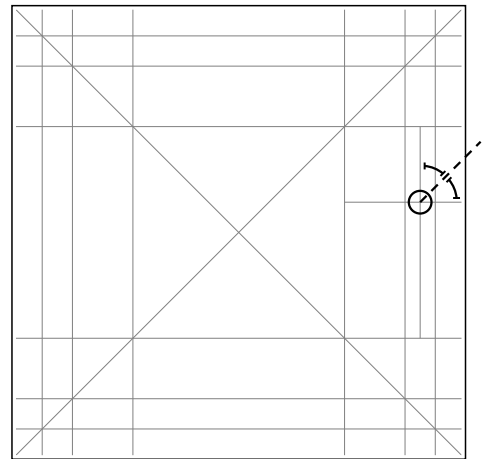

Crease the angle bisector.

7.

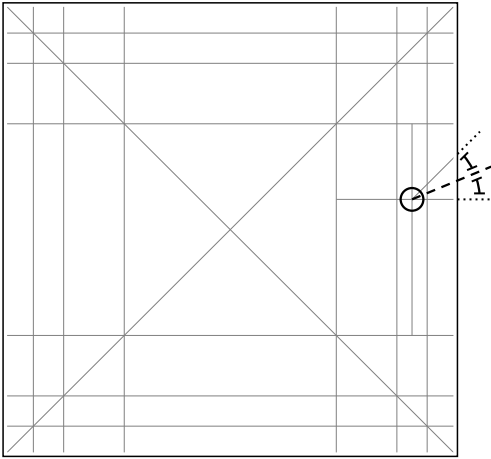

Crease the angle bisector.

8.

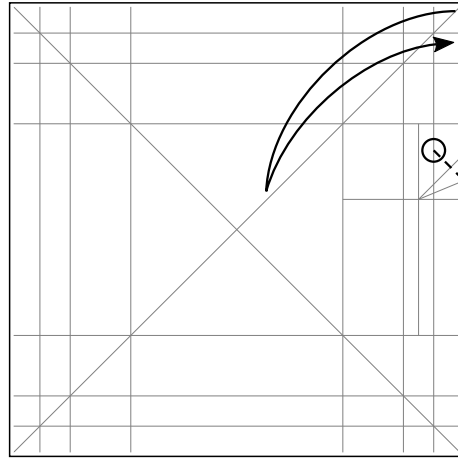

Bring the corner to the crease and crease up to the circled point.

9.

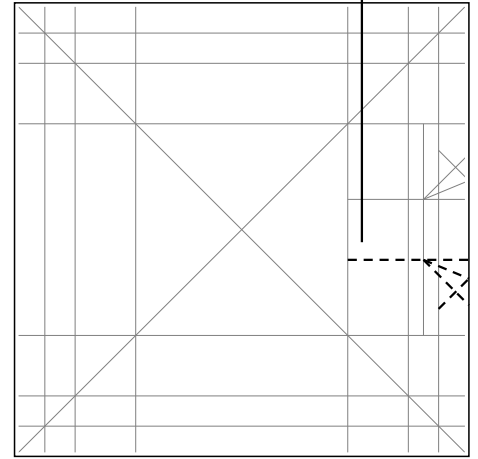

Repeat Steps 5-8 on the bottom.

10. 4-9

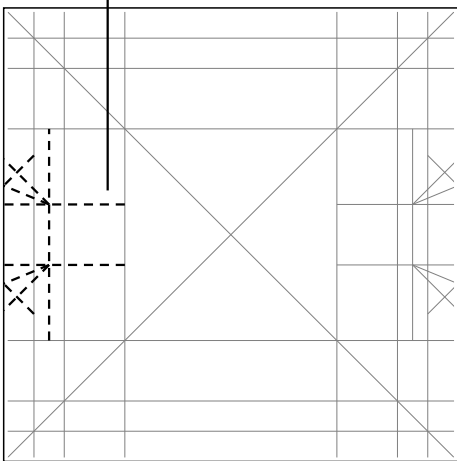

Repeat Steps 4-9 on the left.

11.

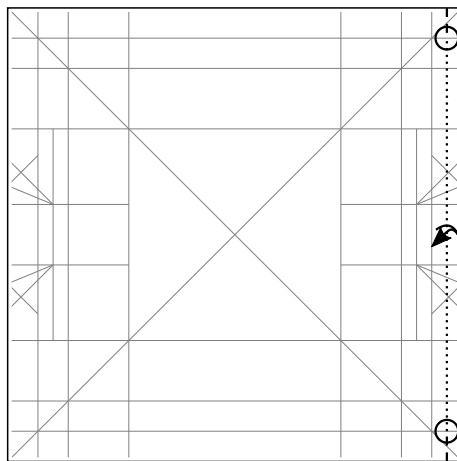

Bring the edge to the crease and crease on both sides.

12.

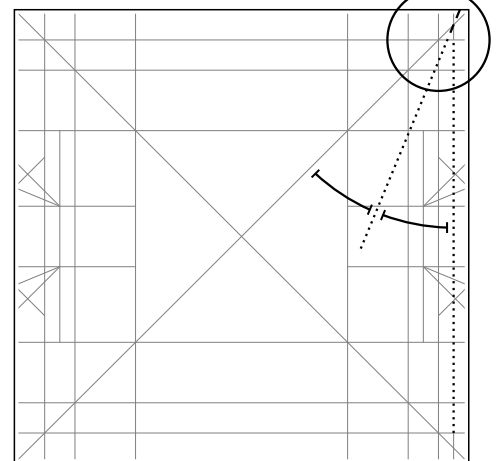

Make a small crease along the angle bisector. Zoom in.

13.

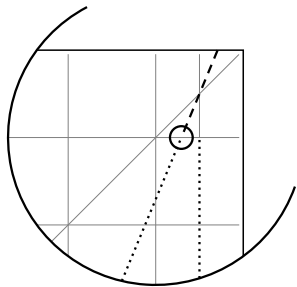

Zoom-in view.

14.

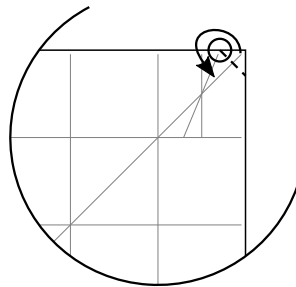

15.

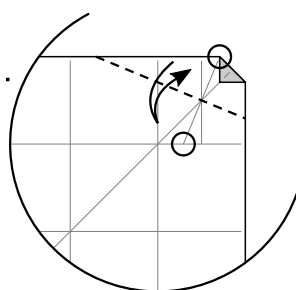

Bring the circled points together and crease. Zoom out.

16.

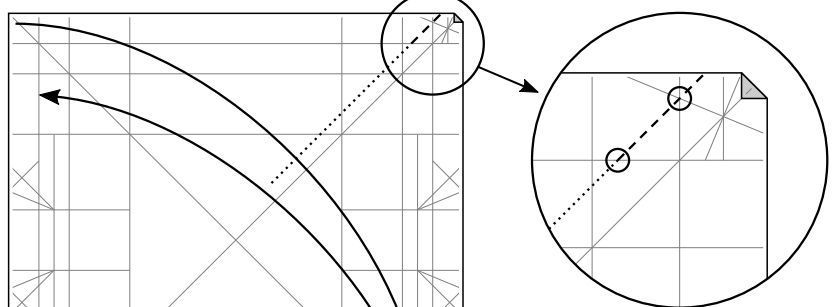

Crease at the crease made in Step 16.

17.

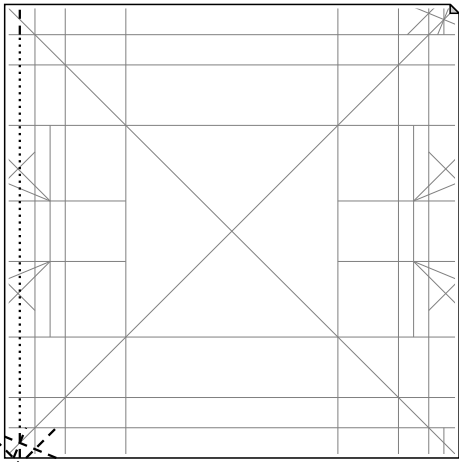

18.

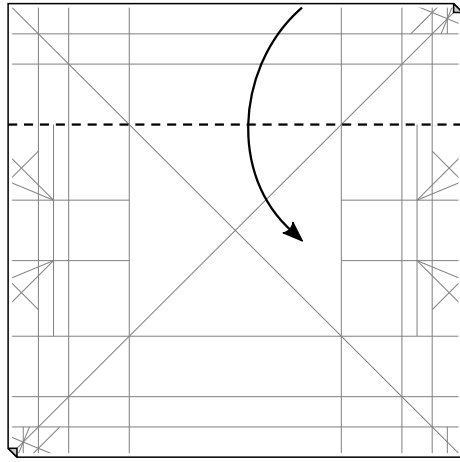

19.

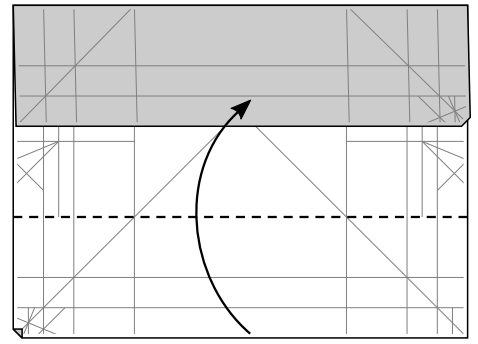

12-17

Repeat Steps 12-17 on the opposite side.

20.

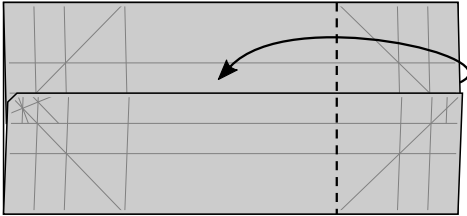

21.

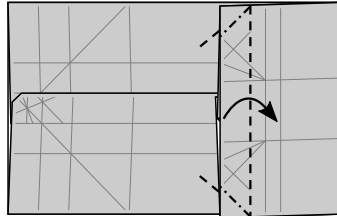

Swivel-fold.

22.

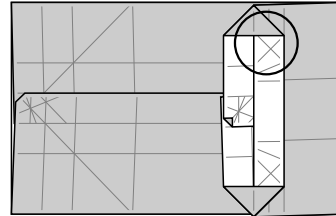

Like this. Zoom in.

23.

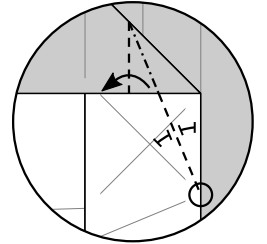

Swivel-fold the angle bisector.

24.

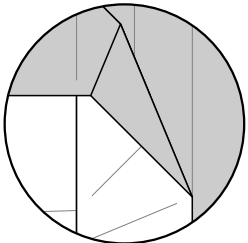

Like this. Zoom out.

25.

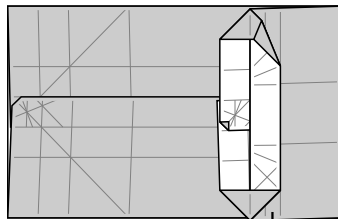

Repeat Step 23 on the bottom. 23

26.

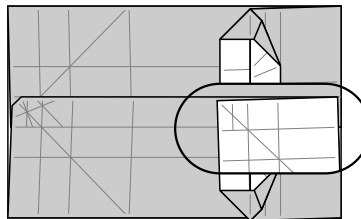

X-ray view.

27.

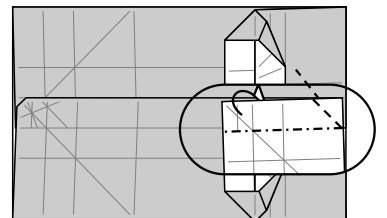

Swivel-fold inward.

28.

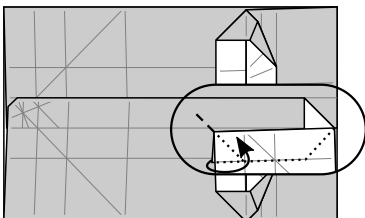

Fold just the layer behind inward to hide the wrong-color seam.

29.

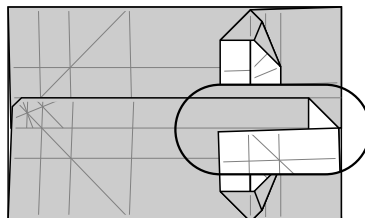

Like this. Return to normal view.

30.

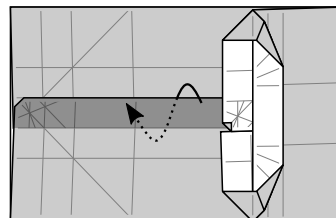

Tuck the edge underneath.

31.

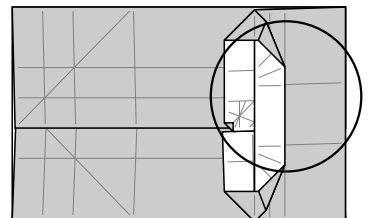

Like this. Zoom in.

32.

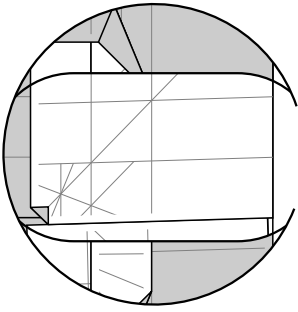

X-ray view.

33.

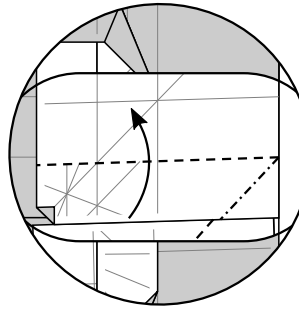

Swivel-fold.

34.

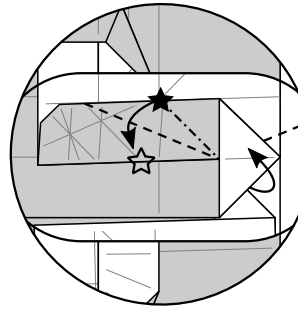

Crimp and squash the model flat.

35.

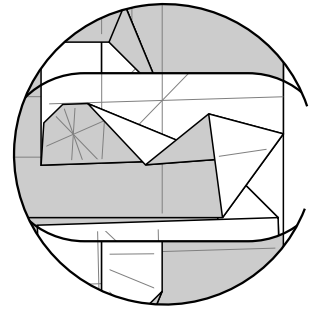

Like this. Return to normal view.

36.

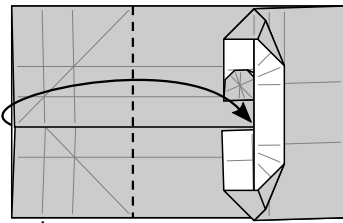

Repeat Steps 20-34 on the other side.

37.

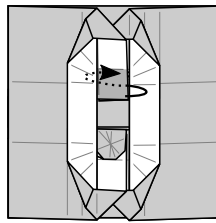

Tuck the corner one layer underneath.

38.

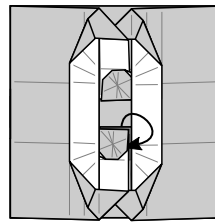

Un-tuck the corner one layer over to hide the wrong-color seam.

39.

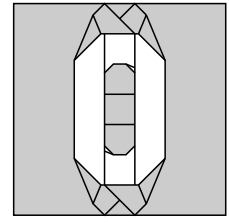

Finished!